

---

# Table of Contents

## E65 Power Module

Subject	Page
<b>Power Module</b> .....	<b>4</b>
<b>Power Module and Voltage Supply Components</b> .....	<b>5</b>
Location and Construction of the Power Module .....	5
Power Supply Circuit .....	6
Positive Battery Cable .....	7
Battery .....	8
Construction .....	9
How it Works .....	9
Service Instructions for AGM Batteries .....	9
Charging .....	9
Installation Location .....	10
Do Not Open .....	10
Battery Replacement .....	10
Fuses .....	10
Luggage Compartment Fuses .....	11
Interior Fuses .....	11
Electronic Battery Master Switch .....	12
High Current Terminals (RADSOK) .....	12
Power Module Inputs .....	13
Terminal 30 .....	13
Battery Switch .....	13
Interior Lighting Button .....	13
Exterior Trunk Lid Release Button (TOEHK) .....	13
Trunk Lock Actuator Switch .....	13
SCA Contact .....	13
15_w (Wake-up) .....	13
Battery Temperature Sensor .....	13
K-CAN Periphery .....	13
Outputs Connected to Electronic Battery Master Switch .....	14
Terminal 30U .....	14
Terminal 30B .....	14
Outputs not Connected to Electronic Battery Master Switch .....	14
Fuses .....	15

<b>Subject</b>	<b>Page</b>
<b>Power Module Functions</b> .....	<b>16</b>
Optimum Charging .....	16
Battery Charge Level Detection .....	16
Temperature-Dependent Battery Charging Voltage .....	16
Increasing Idle Speed to Improve Battery Charging .....	17
Load-Circuit Peak Reduction .....	18
Priority Table for Load-Circuit Peak Reduction and Shut-Down Modes .....	19
Shut-Down of Consumer Circuits in the Event of Low Voltage .....	20
16 Minute Shut-Down of Consumer Circuits (Sleep mode) .....	21
Shut-Down of Auxiliary Consumers .....	21
Auxiliary Consumers and Terminal R .....	22
Auxiliary Consumers and Terminal 0 .....	22
Closed-Circuit Current Monitoring (Standby Current) .....	23
 <b>Closed Circuit Consumer Monitoring and Vehicle Sleep Mode</b> ..	 <b>24</b>
Storage Mode .....	25
Electronic Fuse .....	25
Central Battery Voltage Notification .....	26
Rear Window Heater (HHS) .....	26
Interior Lighting .....	26
Trunk Lid and Fuel Filler Flap Control .....	26
Data Memory .....	27
Emergency-Mode Functions .....	27
Battery Temperature Sensor .....	27
Battery Switch .....	27
Terminal 15w .....	27
Bus Communication .....	27
Summary of Check Control Messages for Power Module .....	28
 <b>Workshop Hints</b> .....	 <b>29</b>
Battery Charging .....	29
Cigarette Lighter Battery Charging Function .....	29
Diagnosis .....	30
Service Functions .....	30
Sleep Mode Activation .....	30
Battery Replacement Registration .....	30
Transport Mode Clearing .....	30

---

# E65 Power Module

**Model: E65, E66**

**Production: All**

# OBJECTIVES

After completion of this module you will be able to:

- Identify and locate the power module and related components
- Understand power module functions
- Perform closed-circuit current diagnosis
- Perform service related functions on the power module

---

## Power Module

The Power Module (PM) is one of the innovative new developments on the E65. The job of the Power Module is to ensure that the battery charge level is maintained when the engine is running and when the vehicle is at rest. The Power Module is also responsible for maintaining the power supply (in the event of faults in the electrical system) to important vehicle systems by disconnecting lower priority circuits.

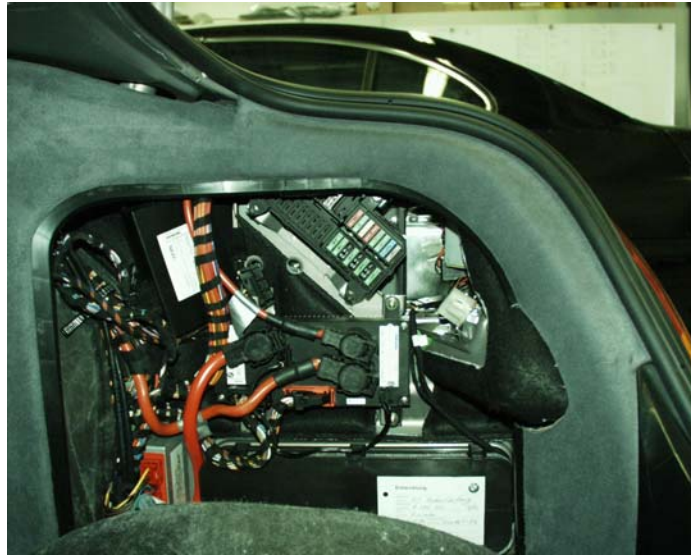

The PM functions include:

- Optimum charging
- Load-circuit peak reduction
- Shut-down of auxiliary consumer circuits in the event of low voltage
- Closed circuit current monitoring
- Distribution mode
- Automatic electrical system isolation
- Load cutout
- Electronic fuses
- Central battery voltage notification
- Rear window defogger output
- Interior lighting control
- Trunk lid and fuel filler flap control
- Data memory storage
- Emergency-mode functions
- Check Control messages
- Diagnosis

## Power Module and Voltage Supply Components

The power supply components in the E65 include:

- The power supply circuit
- Vehicle Fuses
- The power module

### Location and Construction of the Power Module

The power module is located on the right hand side of the luggage compartment behind the trim panel (above the battery).

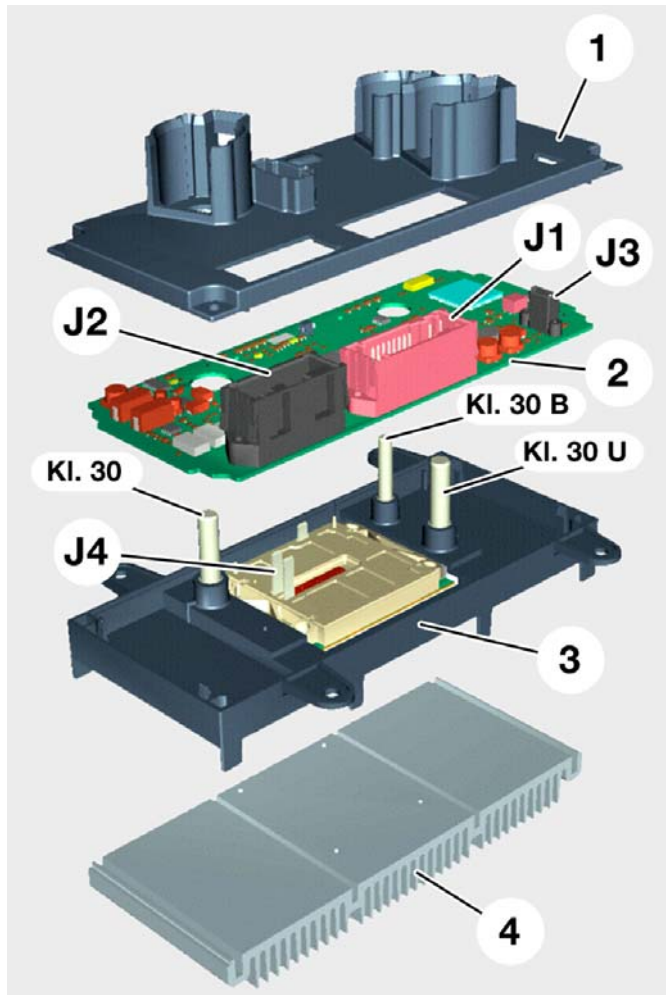

Index	Explanation
1	Cover Plate
2	Electronics
3	Baseplate
4	Heat Sink
J1	Connector
J2	Connector
J3	
J4	Battery Master Switch
KL30	Continuous B+
KL30B	Glove compartment fuse box power supply from master switch
KL30U	Luggage compartment fuse box power supply from master switch

## Power Supply Circuit

The power supply for the general electrical system is controlled by the power module.

The high amperage fuses located in the engine compartment, the generator and the starter motor are connected directly to the battery and are not supplied by the Power Module.

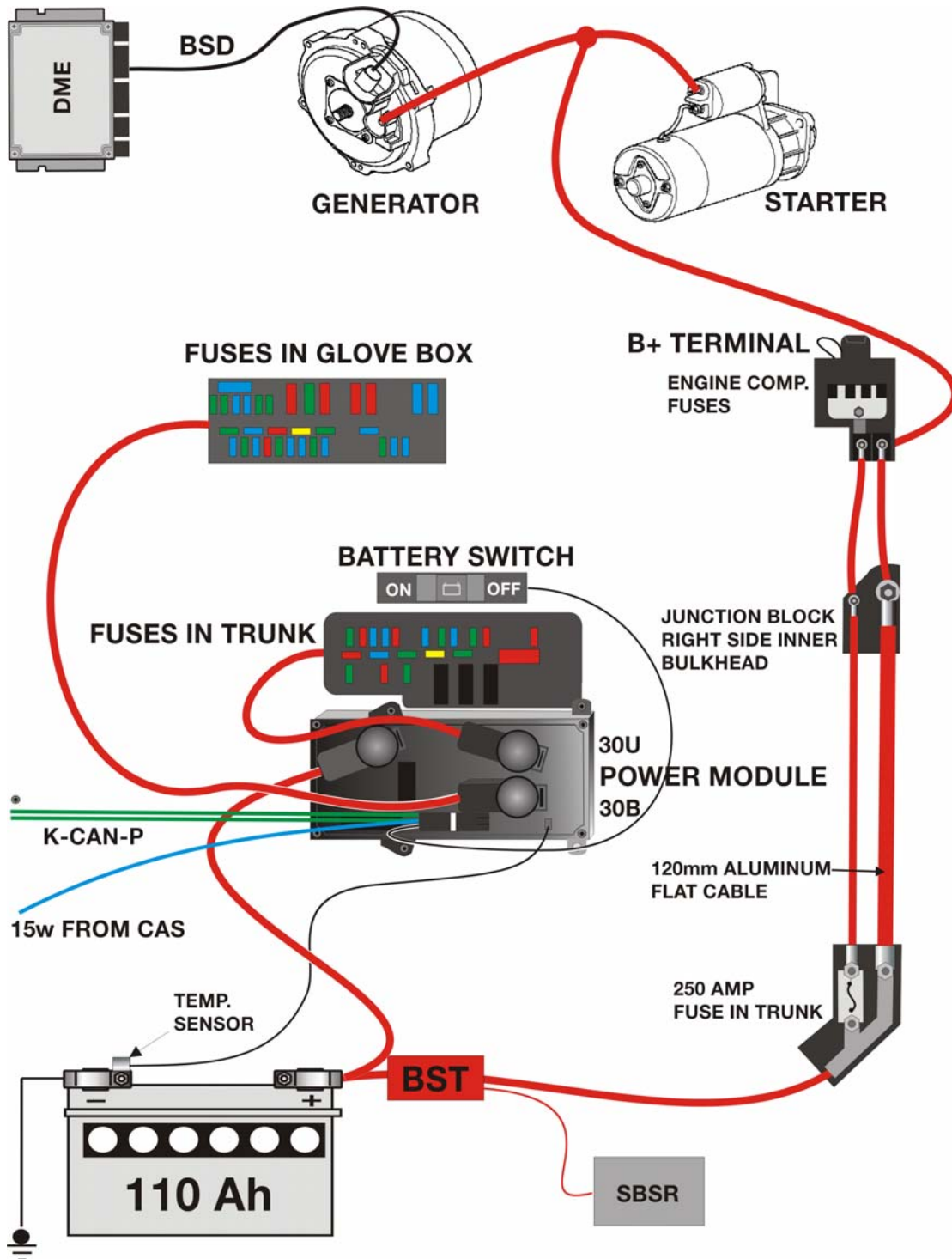

### Positive Battery Cable

An aluminum battery cable in the E65 is used for the first time by a BMW automobile. The cable is flat (120mm<sup>2</sup>) and runs along the vehicle interior from a junction box ahead of the spare tire well to the interior side of the front bulkhead. A smaller copper cable runs parallel to it in the vehicle interior. That smaller cable is supplied via a 250 amp fuse located inside the same junction box that feeds the aluminum cable.

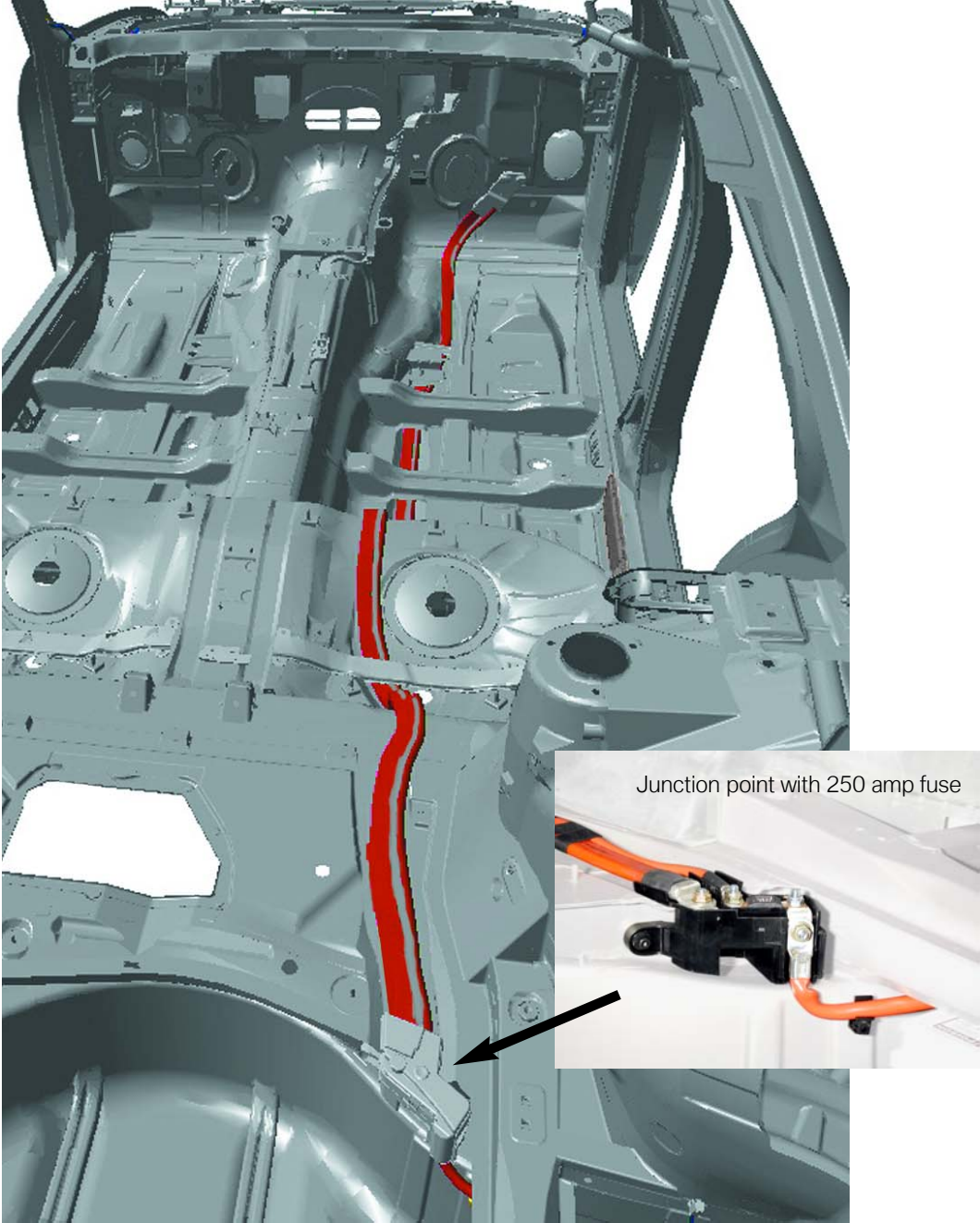



## Battery

From the start of production, the E65 was fitted with a single maintenance free battery (12V/110AH). The battery is located in the right hand side of the trunk below the vehicle jack.

As of September 2002 production, the E65/E66 was fitted with new battery technology. The AGM batteries are now standard equipment. (AGM stands for Absorbent Glass Mat) The AGM battery variant is a 90 Ah unit and can be identified by the black plastic casing as opposed to the white casing on conventional lead-calcium batteries.

AGM batteries are more expensive to produce, however this extra cost is offset by the following benefits:

- Greatly enhanced service life
- Improved starting reliability at low temperatures
- Reliable starting of engine with high starting current requirements
- 100% maintenance free
- Low environmental risk in the event of an accident

In contrast to conventional lead-calcium batteries, the sulphuric acid in an AGM battery is not held freely in the battery housing.

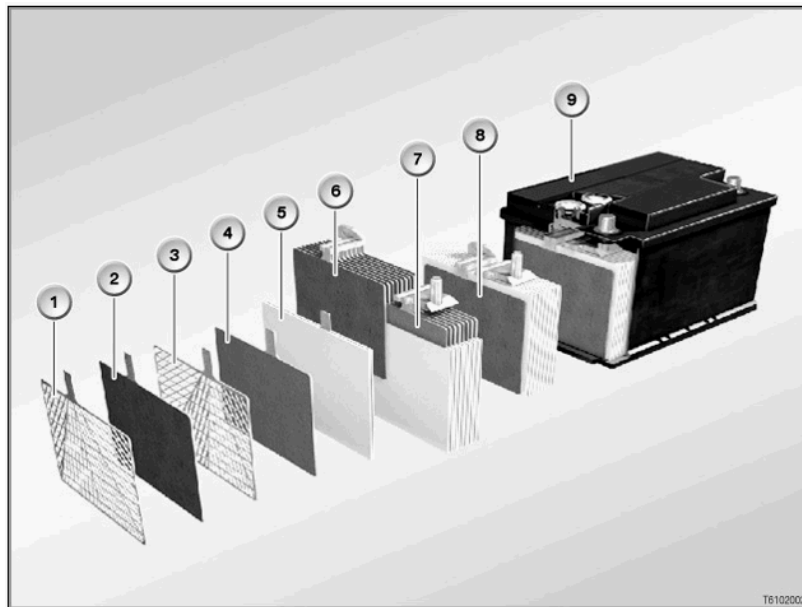

Index	Explanation	Index	Explanation
1	Positive grill with silver alloy	6	Set of positive plates
2	Positive plate	7	Set of negative plates
3	Negative grill	8	Block of plates
4	Negative plate	9	Block box with base strips
5	Separator made of glass fiber fleece		



---

The sulphuric acid is instead entirely bound into the mats of the glass-fibre fleece. For this reason, no acid can escape if the battery housing is damaged. In addition, the AGM battery is a sealed, airtight unit. This is possible because the gasses are converted back into water by the permeability of the separators.

## Construction

AGM batteries differ from conventional lead-calcium batteries in the following points:

- Larger plates which allow a power density some 25% greater.
- Glass-fiber-fleece separators which enables a cycle consistency up to 3 times greater to be achieved which improves cold-starting ability, current consumption and service life.
- Airtight housing with pressure relief valve
- The inspection plugs are sealed and cannot be opened.
- Acid bound in glass-fiber fleece:

## How it Works

AGM batteries differ from conventional lead-calcium batteries in their environmental compatibility and their retention of gases during charging. When a vehicle battery is charged, the electrolysis process emits the gases oxygen and hydrogen.

In a conventional lead-calcium battery, these two gases are released into the atmosphere.

In an AGM battery, the two gases are converted back into water: The oxygen created at the positive electrode during charging moves through the permeable glass-fiber fleece to the negative electrode, where it reacts with the hydrogen ions that are brought in with the electrolyte, to create water (oxygen cycle). In this manner, the gases, and thus the electrolyte, is not lost.

Only when the gas production is excessive, that is when too much pressure is generated (20 to 200 mbar), does the pressure-relief valve open, thereby allowing gas to escape while also preventing entry of atmospheric oxygen. Because the pressure in the battery is regulated by a valve, the AGM battery is also known as the VRLA battery (valve-regulated lead acid).

## Service Instructions for AGM Batteries

When handling AGM batteries, certain special factors must be taken into consideration with regard to battery renewal and installation location.

## Charging

**Warning!!!**

**Do not charge AGM batteries with 14.8 volts!  
Do not use rapid charging programs!**

When charging batteries in the "stand alone" mode, the maximum charge voltage of 14.8 volts must not be exceeded. Even briefly charging an AGM battery with a charge voltage of more than 14.8 volts (voltages usually used in rapid charge programs) will damage the battery.

## Installation Location

**Warning!!! Do not install AGM batteries in the engine compartment!**

Because of large temperature variations, AGM batteries must not be installed in the engine compartment. This would result in a significant reduction in the service life of the battery.

## Do Not Open

**Warning!!! Do not open AGM batteries**

On no account should AGM batteries be opened, as oxygen from the atmosphere would cause the battery to lose its chemical balance and cause it to fail.

## Battery Replacement

An AGM battery, when installed as original equipment, must always be replaced with an AGM battery.

In special cases, where a customer's driving profile (e.g. short distance driving), results in a discharged battery, the AGM battery is a recommended replacement. Note that replacement batteries resulting from a customer's driving profile cannot be claimed under warranty.

## Fuses

The locations of the fuses are as follows:

Engine Compartment

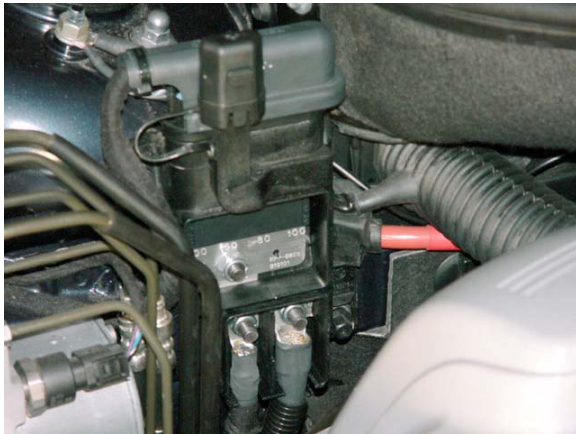

### Next to jump-start connection point

- F101 100 A IVM (Engine/DME Supply)
- F102 50A Secondary Air Pump
- F103 80A Auxiliary Fan
- F104 100A IVM (Engine/DME Supply)

**Note: Fuses 101-104 is a bus strip that is replaced as a complete unit if one circuit is blown.**



### Right side of engine compartment inside the Integrated Voltage Supply Module (IVM).

## Luggage Compartment Fuses

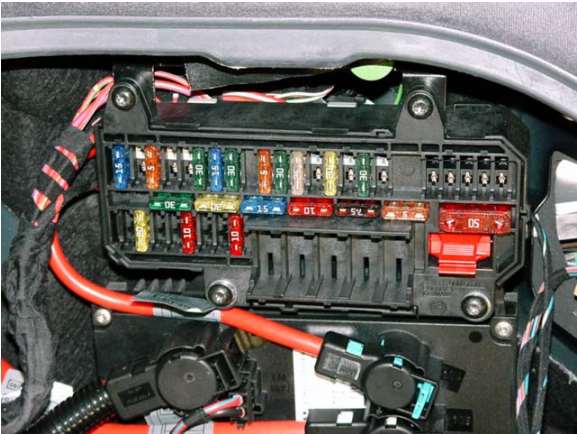

Right side of luggage compartment - fuses 51-84



Junction point with 120mm<sup>2</sup> aluminum flat cable , 250 Amp fusible link (F-200)

## Interior Fuses



Glovebox - Fuses 1-44

Apart from the fuses referred to above, certain control units have integrated electronic fuses which protect components which are directly connected to the control unit.

---

## Electronic Battery Master Switch

The electronic battery master switch is made up of 4 MOSFET output stages (S Bat) and connects the input terminal 30 with the outputs KL30U and KL30B on the Power Module.

The following functions are controlled by means of the power module according to the position of the battery switch:

- Storage mode
- Closed circuit current monitoring
- Electronic fuses
- Automatic electrical system isolation

## High Current Terminals (RADSOK)

New high current terminals are used for the first time. The high current terminals are on the input terminal 30 and the outputs terminal 30U and 30B. These contacts are capable of carrying current peaks (short term) of 220A.

Advantages:

- Continuous load capacity of up to 100A
- Excellent and consistent current conduction over long periods
- Low contact resistance
- Low voltage drop even in the event of a large temperature rise
- Consistently good spring characteristics
- Contacts are self cleaning

The contact are coated in a silver alloy. As compared to tin, nickel, gold and copper, silver has the lowest specific electrical resistance.

In spite of high currents, the high current sockets are not soldered to the cable, as a special crimping technique ensures an excellent connection.

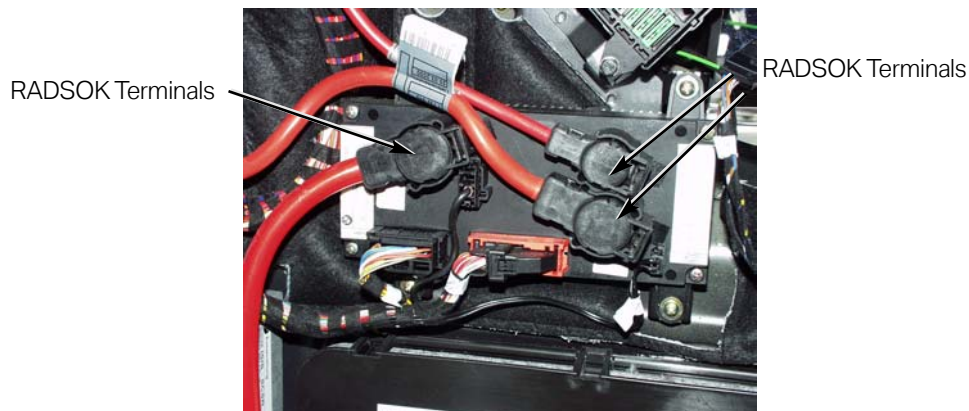

---

## Power Module Inputs

### Terminal 30

The battery positive terminal is connected directly to the load input of the Power Module.

### Battery Switch

The battery switch (BS) offers the vehicle owner and the service department the choice between the settings ON ("closed circuit current monitoring") and OFF ("storage mode"). It is located above the PM on the right hand side of the luggage compartment.

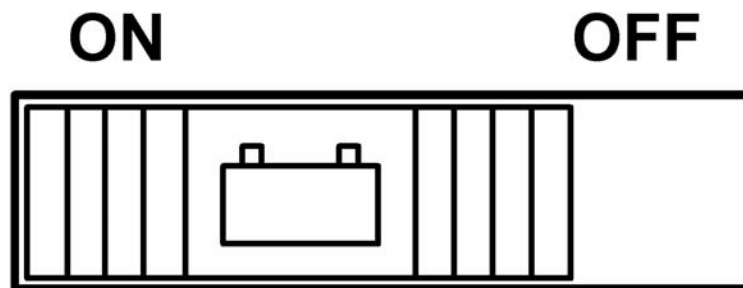

### Interior Lighting Button

This controls the interior lighting and is located on the front interior lighting unit. The possible settings are "Automatic control", "On", "Off" and "Workshop mode" (hold for 3 seconds).

### Exterior Trunk Lid Release Button (TOEHK)

This button is a direct input to the Power Module. The trunk lid is released by means of the button on the outside of the trunk lid.

### Trunk Lock Actuator Switch

The switch in the trunk lock actuator is used to inform the Power Module as to the position of the lock actuator and to synchronize the SCA. It also controls the luggage compartment lighting, the monitoring of the alarm system and the trunk lid warning light.

### SCA Contact

This input is used to signal the PM that the SCA has rotated 180° (used to switch the electric motor).

### 15\_w (Wake-up)

This is a redundant signal from the Car Access System which wakes up the Power Module.

### Battery Temperature Sensor

Measures the temperature directly on the battery negative terminal. This information is used for the "optimum charging" function. The measuring range is -25°C to +75°C.

### K-CAN Periphery

Enables communication with the vehicle network.

---

## Outputs Connected to Electronic Battery Master Switch

### Terminal 30U

Supplies the fuse box in the luggage compartment.

### Terminal 30B

Supplies the fuse box in the glove compartment.



## Outputs not Connected to Electronic Battery Master Switch

The following outputs are supplied by the PM separately from the electronic battery master switch:

- Rear window heater (HHS)
- Light Module (LM)
- Car Access System (CAS)
- DME
- Alarm system (DWA)
- Emergency power siren (SINE)
- Cigarette lighter (ZIG)
- Electro-chromatic mirrors (EC)
- Park Distance Control (PDC)
- Rain/light sensor (RLS)
- Interior lighting (IB)
- Central locking trunk lid drive (ZV)
- Central locking, fuel filler flap (ZV)
- Trunk lid Soft Close Motor (SCA)







---

## Power Module Functions

### Optimum Charging

The battery voltage can fluctuate between 14.0 V and 15.5 V. The optimum charge voltage is set according to the charge level of the battery, the battery temperature and the status of the external lights (higher charging voltage with lights off). The maximum setting is 16 V.

### Battery Charge Level Detection

The Power Module knows what the charge level of the battery is at any time by calculating the battery current when the vehicle is being driven and measuring the discharge current.

When the vehicle is not in use, the charge level is re-calculated and updated by measuring the closed circuit battery voltage. If the vehicle battery is replaced it must be registered with the Power Module so that the stored values can be deleted and a new calculation started. This operation is described in "Service Functions".

### Temperature-Dependent Battery Charging Voltage

By using a charging characteristic map stored in the PM, the charge voltage of the generator is adjusted according to the battery temperature. The diagram below shows the communication path necessary for the Power Module to inform the generator to increase or decrease charge voltage output.

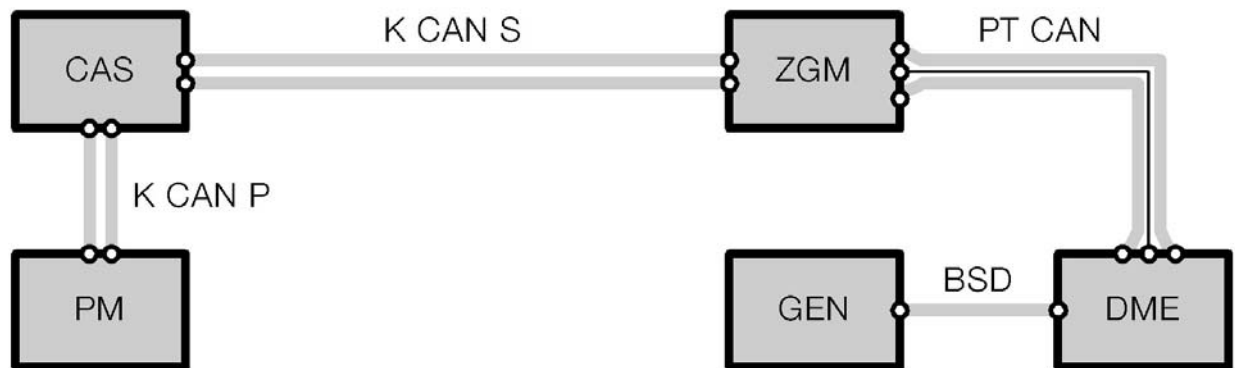

The Power Module detects the temperature of the battery and places the instruction "Increase charge voltage" on the K-CAN Periphery. The Car Access System (CAS) passes the message on to the K-CAN System bus.

The Central Gateway Module (ZGM) receives the message. Performing its function as a "gateway control unit", it passes the message on to the PT-CAN.

The DME (ECM) module receives the request to increase the charge voltage over the PT-CAN.

The generator then receives the request to increase the charge voltage via the BSD lead (bit serial data interface). The electronic evaluation unit in the generator then adjusts the charge voltage accordingly.

If the temp. sensor is detected as defective then the charging voltage will be fixed at 14.3V.

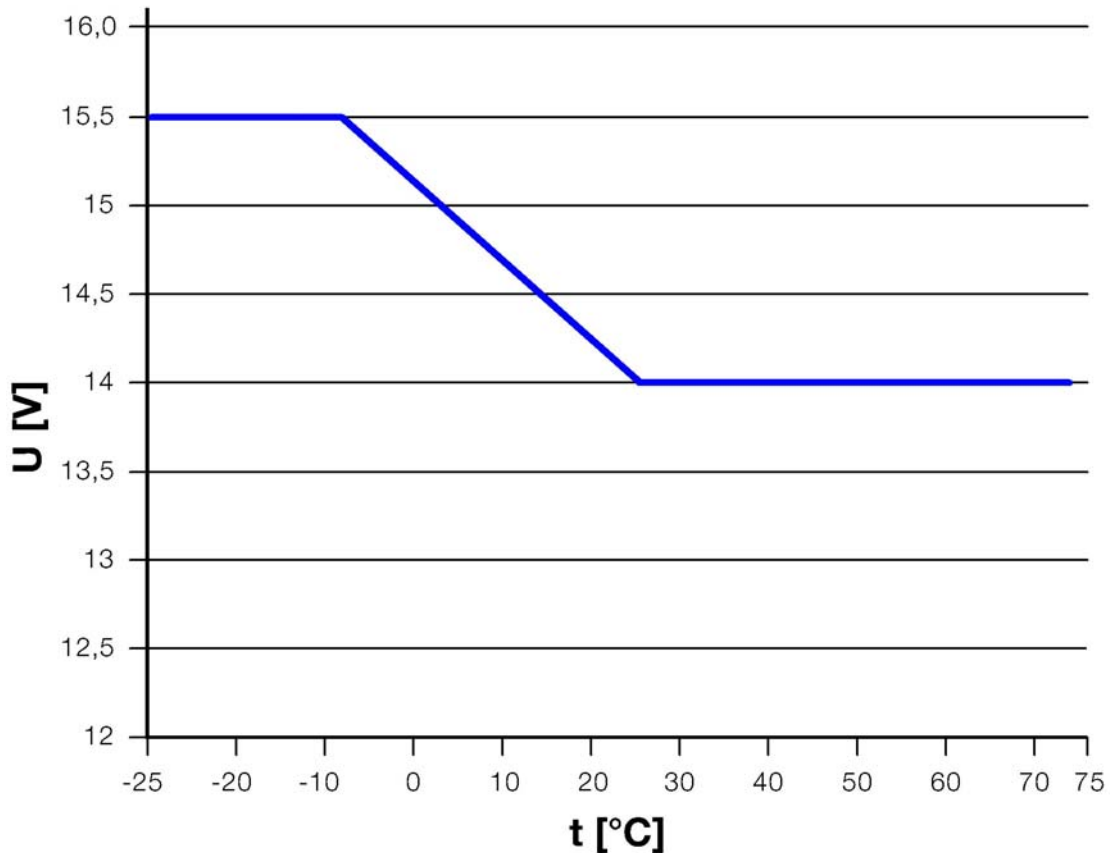

### **Increasing Idle Speed to Improve Battery Charging**

In order to drain as little energy as possible from the battery during freezing weather (below 34°F) the idling speed may be increased.

This ensures that the battery charge level is kept high. If the charge level falls below the calculated minimum level for starting, the idling speed is increased to 750 rpm.

The calculation of the minimum level for starting takes account of the temperature and the condition/age of the battery.

## Load-Circuit Peak Reduction

If battery discharge is detected while the engine is running (despite increased idling speed), the power supply to electrical consumer circuits are gradually reduced or completely shut off according to a table of priorities. The consumer systems concerned are divided into two groups: Priority group A and Priority group B.

Priority Group A	Priority Group B
Rear window heater	IHKA fan (Except during defrost)
Headlight washing	Rear IHKA fan (E66 only)
All seat heaters	
Active seat	
Seat ventilation	
Steering wheel heater	
Mirror heater	
Windshield wiper blade heating	
Wet arm heating	

Priority A systems are dependent on battery SoC (State of Charge) and generator output during the operation of the consumer.

Priority B systems are only dependent on the battery SoC.

The Power Module also sends out a telegram indicating the status of the Load-circuit peak reduction function. The priority level of the message is classified by a number 0 through 6 and is as follows:

- 0 = Normal operation without peak reduction (KL 15 "ON")
- 1 = Terminal R "ON" without peak reduction **OR** generator defect or under-voltage acknowledged.
- 4 = Corresponds to maximum peak reduction.
- 5 = Corresponds to medium peak reduction.
- 6 = Corresponds to minimum peak reduction.

The computation by the Power Module to determine which priority level is necessary is based on the battery SoC. Example: the threshold for priority level 6 is a 65% SoC.

Current vehicle priority levels can be displayed in the Diagnosis Program.

## Priority Table for Load-Circuit Peak Reduction and Shut-Down Modes

Legend:

- X = Permitted operation at the priority level concerned
- PM bus telegram priority A devices = Control peak reduction-priority
- PM bus telegram priority B devices = Control peak reduction-comfort
- Priority level:
  - 0= Normal operation without peak reduction (KL 15 “ON”)
  - 1= Terminal R “ON”, generator defect or under voltage acknowledged.
  - 4= Corresponds to max. peak reduction.
  - 5= Corresponds to medium peak reduction
  - 6= Corresponds to minimum peak reduction

Consumer Circuit	Priority Level									
	0		1		4		5		6	
	A	B	A	B	A	B	A	B	A	B
<b>Rear Window Defogger</b>										
Off	X		X		X		X		X	
Intermittent operation	X						X		X	
On	X									
<b>Seat Heaters</b>										
Switched off	X		X		X		X		X	
Temperature level 1	X				X		X		X	
Temperature level 2	X						X		X	
Temperature level 3	X									
Maximum rated output	X								X	
Half rated output	X				X		X		X	
<b>Heater Fan</b>										
Speed 0		X		X						
Speed 1		X				X		X		X
Speed 2		X				X		X		X
Speed 3		X						X		X
<b>Steering Wheel Heater</b>										
Level 0	X		X		X		X		X	
Level 1 (clocked mode)	X						X		X	
Level 2 (fast heat up)	X								X	
<b>Mirror Heater</b>										
Off	X		X		X		X		X	
On	X									

Consumer Circuit	Priority Level									
	0		1		4		5		6	
	A	B	A	B	A	B	A	B	A	B
<b>Windshield Heater</b>										
Off	X		X		X		X		X	
On	X									
<b>Wet Arm Heater</b>										
Off	X		X		X		X		X	
On	X									
<b>Headlight Washer System</b>										
Off	X		X		X		X		X	
On	X									
<b>Active Seat</b>										
Off	X		X		X		X		X	
On	X								X	
<b>Seat Ventilation</b>										
Off	X		X		X		X		X	
On	X						X		X	

### Shut-Down of Consumer Circuits in the Event of Low Voltage

If the battery voltage drops below 10.5 V (for 5 seconds) due to high load levels, the Power Module sends out an instruction to increase the idling speed and to activate prioritized shut-down of electrical consumer circuits.

At the same time, the power outputs of the Power Module (interior lighting, consumer isolation circuit in roof/body zone) are switched off.

The following Check Control message appears:

Check Control Message Displayed in KOMBI	Message displayed in Control Display	Cause
Power Module! Drive Moderately	Power Module in emergency operating mode. Electrical power supply limited. Please contact nearest BMW center.	Power Module conducting emergency shut down mode
CC Symbol Displayed 		

---

## **16 Minute Shut-Down of Consumer Circuits (Sleep mode)**

To prevent battery discharge by consumer items mistakenly left on, the interior lighting circuit (IB) and consumer circuits-roof zone (VA-D) are shut off 16 minutes after terminal R is switched off.

## **Shut-Down of Auxiliary Consumers**

Auxiliary consumer circuits are items such as the CD, DWA, LM, EGS and IHKA (rest function).

In order to ensure that the car is capable of starting, the charge level (SoC-State of Charge) of the battery is monitored when the vehicle is at rest.

The minimum battery SoC required to ensure that the car can be started again is a calculated value. The calculation takes into account the:

- Battery temperature measured over last few days
- Engine type
- Capacity of the battery fitted (110Ah for the 745i).

The SoC calculation is displayed as a percentage of battery capacity ( A fully charged battery is considered 80%).

If the charge level of the battery gets close to that calculated minimum level as a result of the operation of an auxiliary consumer unit, the Power Module instructs that circuit to switch off.

Two modes of operation are distinguished when shutting down auxiliary consumer circuits:

- Auxiliary consumer with terminal R on.
- Auxiliary consumer with terminal 0 (ignition off).

## Auxiliary Consumers and Terminal R

When terminal 15 changes to terminal R, the message Priority level 1 is broadcast. Reduction of power consumption if necessary is then controlled on the basis of the table on page 18 and 19.

The charge level of the battery is calculated. If it is still below the minimum level for starting the car, the following Check Control message appears:

Check Control Message Displayed in KOMBI	Message displayed in Control Display	Cause
Recharge Battery! 	Recharge Battery! Battery heavily discharged. Charge by driving for longer period or by using external charger. Battery will be disconnected soon.	Battery discharged

If the charge level does not improve, after 5 minutes the PM issues the "Shutdown counter" message (shut-down message is to inform modules to store any information prior to power being switched off). After a further 90 seconds, the vehicle's electrical system is shut down.

This is on condition that no safety related consumers are switched on.

If safety related consumers are on (e.g. hazard lights), the battery is not disconnected from the electrical system when the minimum battery SoC for starting the car is reached. The battery is allowed to fully discharge.

## Auxiliary Consumers and Terminal 0

If the driver switches on an auxiliary consumer it logs itself on by issuing the message "Auxiliary consumer power management". By doing so, it triggers the PM to precisely calculate the battery charge level.

Following a successful log-on, the auxiliary consumer goes into operation and the charge level of the battery is monitored.

If the charge level falls below the minimum level for starting the car, the following Check Control message appears:

Check Control Message Displayed in KOMBI	Message displayed in Control Display	Cause
Recharge Battery! 	Recharge Battery! Battery heavily discharged. Charge by driving for longer period or by using external charger. Battery will be disconnected soon.	Battery discharged

Five minutes later, if no legally required consumers are switched on, the PM automatically switches to "closed-circuit current monitoring" mode.



## Closed-Circuit Current Monitoring (Standby Current)

When terminal 0 is active, the PM switches over to closed-circuit current monitoring after 60 minutes. If an operation is performed on the car before 60 minutes has elapsed (e.g. central locking, trunk opened), the timer starts from the beginning again.

Once that period has ended, the closed-circuit current should not exceed 80 mA. If the closed-circuit current exceeds 80 mA, after 5 minutes the PM issues the "Shutdown counter" message. After a further 90 seconds, the vehicle's electrical system is shut down for 5 seconds.

If the quiescent current still exceeds 80 mA when the system is switched on again, the sequence described above is repeated. If the quiescent (sleep) current is then still over 80 mA, the system is permanently shut down via the electronic battery master switch.

The fault is recorded in the Power Module's fault memory (with details of environmental conditions and cause).

When the signal "15w" from the CAS is detected, the electronic battery master switch is closed and the following Check Control message is displayed:

Check Control Message Displayed in KOMBI	Message displayed in Control Display	Cause
High standby current! 	High standby current! Vehicle electrical accessories are drawing excessive passive state current. Battery has been disconnected, Please contact your BMW center.	Excessive closed circuit current draw.

Closed-circuit current monitoring is automatically cancelled by a message from the LM that the hazard warning lights are active.

When terminal R is switched off, current monitoring is also immediately activated. Normal current load on the vehicle drops in stages according to the vehicle programming for sleep mode (see the chart on the following page).

If the monitored current is more than 120 amps (even as a random spike), the interior lighting, roof area consumers and body zone consumer circuits are immediately switched off.



## Storage Mode

By switching "OFF" the battery switch, the Power Module goes into Storage Mode 30 minutes after terminal R switches off.

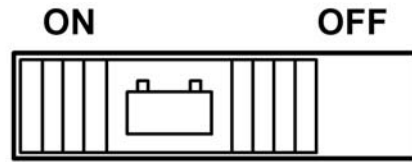

Before disconnecting, the PM sends out the "Shutdown" signal. After a further 90 seconds the shut down is completed. If the ignition switch is turned to terminal R "On", a Check Control message is issued which informs the driver that the vehicle is in Storage Mode.

The following CC message appears:

Check Control Message Displayed in KOMBI	Message displayed in Control Display	Cause
Battery Switch OFF! 	Battery Switch OFF! Re-set battery switch in luggage compartment to ON, refer to owners manual.	Battery switch left in OFF position.

When the signal "15w" or change-over of the battery switch to "closed-circuit current monitoring" is detected, the electronic battery master switch is closed.

The car can still be started and driven in storage mode. All systems remain functional. The CC message remains active.

When "Terminal R Off" is active, disconnection is carried out after 30 minutes (as explained above).

**Note: If no function of any kind is activated over a period of 3 weeks, the battery is disconnected completely from the vehicle's electrical system. This prevents battery discharge. This function is independent of the position of the battery switch.**

## Electronic Fuse

If a short circuit current of over 250 A is detected, the battery master switch is opened.

When the wake-up signal "15w" from the CAS is detected, then an attempt is made to close the battery master switch again.

This procedure is repeated continually until the short circuit has been eliminated.

---

## Central Battery Voltage Notification

The Power Module continuously measures the battery voltage. This information is made available to all other control units via the bus link. This can be used, for example, to enable continuous running of the sliding/tilting sunroof regardless of battery voltage.

Central battery voltage notification eliminates the need for individual measurement of battery voltage by each control unit.

## Rear Window Heater (HHS)

The electronic rear window heater output stage of the PM is activated by a "HHS On" (K-CAN-S via CAS via K-CAN -P) message from the IHKA control unit. Control is directly by the final stage.

## Interior Lighting

The interior lighting is subdivided between three outputs (groups):

- IB (interior lighting)
- VA-K (consumer isolation circuit, body zone)
- VA-D (consumer isolation circuit, roof zone)

The interior lighting is controlled by the PM, the outputs are 12V stabilized-voltage. VA-K and VA-D are switched on/off according to the status of the relevant switches.

## Trunk Lid and Fuel Filler Flap Control

The Power Module controls the following trunk-lid related functions of the body zone electronics:

- Trunk lock actuator
- Trunk lid automatic soft close motor (SCA)
- Fuel filler flap lock actuator

The necessary software, such as on times and repeat lockouts is integrated in the PM. For more details, refer to the chapter: Central Body Electronics.

The PM monitors the trunk lid for the DWA system via the trunk lock actuator (ZV) contact switch.

---

## **Data Memory**

The data memory stores data relevant to the vehicle. That information provides a status read-out of the battery load and life. It can be accessed by way of the diagnosis function.

The data memory will be used in future to obtain a load profile of the battery in normal operation that will be analyzed for the purposes of "condition based servicing."

## **Emergency-Mode Functions**

### **Battery Temperature Sensor**

In the event of a defective sensor, a short circuit or an implausible value, the substitute value of 20°C is assumed. This corresponds to a fixed charge voltage of 14.3 V at the battery.

Battery capacity (SoC) is calculated using the substitute value.

### **Battery Switch**

If a fault is detected in the battery switch, the Power Module switches to Storage mode as if the switch were in the "OFF" position.

### **Terminal 15w**

Shut-down of the PM in the absence of terminal 15w is prevented by the following duplicated signals:





- Terminal 15 (from CAS via bus link)
- Road speed > 2 km/h (from DSC via bus link)
- System voltage > 13.2 V (PM central battery voltage notification)

### **Bus Communication**

If bus communication is not possible, all information is "frozen."

## Summary of Check Control Messages for Power Module

The following is a summary of all of the possible Check Control messages relevant to the Power Module:

Check Control Message Displayed in KOMBI	Message displayed in Control Display	Cause
<b>Battery Switch OFF!</b> 	Battery Switch OFF! Re-set battery switch in luggage compartment to ON, refer to owners manual.	Battery switch left in OFF position
<b>High standby current!</b> 	High standby current! Vehicle electrical accessories are drawing excessive passive state current. Battery has been dis-connected, Please contact your BMW center.	Excessive closed circuit current draw.
<b>Recharge battery!</b> 	Recharge battery! Battery heavily discharged. Charge by driving for longer period or by using external charger. Battery will be disconnected soon.	Battery discharged.
<b>Power Module! Drive moderately.</b> 	Power module in emergency operating mode. Electrical power supply limited. Please contact the nearest BMW center.	Power module in emergency mode.
<b>Power module failure!</b> 	Power module failure! Automatic monitoring of battery charge level failure. Please contact the nearest BMW center.	Power module alive signal missing over bus line.

---

## Workshop Hints

### Battery Charging

As with previous models, a battery charger can be connected in the engine compartment to the battery junction point or directly to the battery in the trunk. The PM detects an external battery charger if the battery voltage is above 13.2 V for 1 hour without the engine running.

Following detection of external battery charging, a battery charge level of 80% is reported even if the charge level is higher or lower than that figure.

### Cigarette Lighter Battery Charging Function

A trickle charger can also be connected to the cigarette lighter. However, the cigarette lighter is supplied by the body-zone consumer isolation circuit (VA-K) via a relay.

If the "terminal R Off" signal is present for more than 60 minutes, that relay will be switched off by the consumer shutdown function. That would mean that a charger connected to the cigarette lighter would be disconnected from the battery.

To prevent this, the consumer shut-down function can be deactivated. This is performed by the following procedure:

Slide the battery switch off and on again twice within two seconds. Starting with the battery switch in the ON position, switch to OFF, Switch ON, Switch OFF and end with the switch in the ON position. Do this within 2 seconds, an the trickle charger can be used to charge the battery through the cigarette lighter.

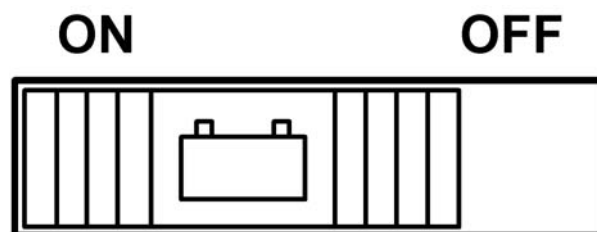

The function is cancelled by: "terminal 15 On" , switching the battery switch from "OFF" to "ON" or failure of the battery voltage to reach 12.6 V after 6 hours of charging.



## **Diagnosis**

All inputs/outputs that are part of the Power Module can be diagnosed by Test Modules or status checked by the Control Unit Functions of the Diagnosis Program. The outputs can also be activated by Component Activation and the power consumption displayed.

The Diagnosis Program is based on the E46 concept.

All electronic fuses and the electronic battery master switch are monitored for short circuits/circuit breaks. In the event of a fault, an appropriate entry is made in the PM's fault memory and, if appropriate, a check control message initiated.

## **Service Functions**

### **Sleep Mode Activation**

This function can be used to put the control units into sleep mode. The battery switch must be set to "ON" when using this feature. The Test module will indicate whether the function was successful or not.

### **Battery Replacement Registration**

This Service Function informs the PM that the battery has been replaced. It completes the following operations:

- The battery capacity is set to 80%.
- The current odometer reading is stored.

The odometer readings at which the last seven battery replacements took place can be read off from the Diagnosis Requests of Control Unit Functions.

- The stored battery statistics (current, voltage, battery charge level) are deleted.
- The stored temperature statistics are deleted.

### **Transport Mode Clearing**

Vehicles that arrive at the BMW centers may have the Transport Mode cleared by using the Test Module under the Service Functions menu. Different from the Storage Mode described on page 24, certain consumers such as the radio, interior lights, and electric windows (except drivers side) are permanently switched off.







## Classroom Exercise - Review Questions

1. What is the maximum charging voltage on an AGM battery?

---

2. List the pathway in which the power module commands the generator to adjust the charging voltage:

---

---

---

---

3. Why is the Power Module responsible for controlling the trunk and filler flap lock actuators?

---

---

---

---

---

4. What information does the Power Module use to calculate the optimum charge voltage?

---

---

---

---

5. Name a feature of the Power Module that is responsible for ensuring that the important systems have power, even if a voltage loss while driving is detected. How can the Power Module react to a loss in power?

---

---

---

---

---

---

---

6. What function must be performed to the Power Module after relacing a battery?

---

---

---

7. How would the driver know that the battery switch was in the OFF position?

---

---

---

8. How is the Power Module informed that an external battery charger has been connected?

---

---

---

---

9. Which control module provides the KL15w (wake-up) signal to the Power Module? What would happen if the wire for the KL15w input were damaged?

---

---

---

---

10. What happens to the engine RPM if the charge level falls below the calculated minimum level for starting?

---

---

---

---

---

---